



The new degree of comfort.™



Residential Electric  
Professional Prestige  
Hybrid Heat Pump Water Heaters

# Professional Prestige™ Hybrid Heat Pump is our most advanced, energy-efficient electric water heater – its 2.45 Energy Factor lowers energy costs

## Efficiency

- High 2.45 EF reduces operating cost \$370 annually compared to a standard 50-gallon electric model
- ENERGY STAR® rated

## Performance

- 8700 Btu/h compressor: the most powerful in its class – more heat can be created by the heat pump and less by the costly electric elements. This translates into significant fuel saving in real life applications. For still more savings, the Rheem hybrid has a wider temperature operating range, which means the heat pump can be used to heat water more days throughout the year.
- Ambient operating range: 37-120° F is widest in class, offering more days of HP operation annually; designed to meet Northern Climate Spec (Tier 1)

## Operation Modes

- Energy Saver
- Heat Pump Only
- High Demand
- Electric Heat Only
- Vacation: 2-28 days (or placed on hold indefinitely)

## Full-Color LCD Display



- Intuitive, back lit touch screen with diagnostics

## Easy Installation

- Easy access side connections
- Narrow 21" diameter, fits through access doors
- Easily replaces a standard electric water heater

## Plus...

- EcoNet™ compatible for future integration with home automation, energy management and demand response systems
- Patented magnesium anode rod with resistor extends the life of the tank
- 3/4" NPT water inlet, outlet and condensate drain connections
- Incoloy stainless steel resistor elements
- Dry-fire protection
- Easy access, top mounted washable air filter
- 2-1/2" Non-CFC foam insulation
- Enhanced flow brass drain valve
- Temperature and pressure relief valve included
- Low lead compliant

## Warranty

- 12-Year limited tank and parts warranty\*

\*See Residential Warranty Certificate for complete information

Units meet or exceed ANSI requirements and have been tested according to D.O.E. procedures. Units meet or exceed the energy efficiency requirements of NAECA, ASHRAE standard 90, ICC Code and all state energy efficiency performance criteria.

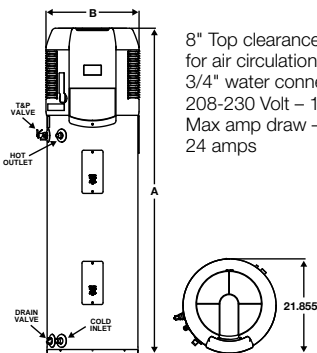

5 ProClub POINTS

**Professional Prestige Hybrid Heat Pump**  
50-Gallon Capacity  
208-230 Volt / 1 PH / 24 Amps  
Electric



LEED Points = 3

[myrheem.com/proclub](http://myrheem.com/proclub)

| TYPE | DESCRIPTION |              | FEATURES         |                          |                               | ROUGHING IN DIMENSIONS (SHOWN IN INCHES) |            |                |                        | ENERGY INFO. |                              |
|------|-------------|--------------|------------------|--------------------------|-------------------------------|--|------------|----------------|------------------------|--------------|------------------------------|
|      | GAL. CAP.   | MODEL NUMBER | COMPRESSOR BTU/H | FIRST HOUR RATING G.P.H. | RECOVERY IN G.P.H. 90° F RISE | HEIGHT A                                 | DIAMETER B | UNIT WT. (LBS) | APPROX. SHIP WT. (LBS) | ENERGY SAVER | ESTIMATED YEARLY ENERGY COST |
| Tall | 50          | HB50RH       | 8700             | 57                       | 21                            | 75-1/2                                   | 21         | 180            | 226                    | 2.45 EF      | \$215                        |

Standard 50-gallon tank defined as a standard 50-gallon electric water heater with an EF of .90. Estimated energy cost based on a national average electricity cost of 12.00 /kWh. Energy Factor determined by U.S. Department of Energy (DOE) test procedures.



INTEGRATED HOME COMFORT



The new degree of comfort.™



Residential Electric Professional Prestige Hybrid Heat Pump Water Heaters

### Full-Color LCD Display Screens



Start Up Screen

Press "Standby" to start

**Energy Saver Mode 1**  
Best energy efficiency for typical hot water demands  
**Home Screen**  
Factory set to default to the "Energy Saver" mode screen



#### Modes 2-5



**HP Only Mode:**  
Provides highest energy efficiency when hot water demands are low



**High Demand Mode:**  
Right selection for very high demand (simultaneous operation of multiple hot water fixtures)



**Electric Heat Mode:**  
Operates like a standard electric water heater; no heat pump



**Vacation Mode:**  
Can be set from 2 to 28 days (82°) or placed on "hold" indefinitely

#### Settings



- Select scale: Fahrenheit or Celsius
- Lock or unlock the home screen; Setting screen remains unlocked
- Enable/disable beeping alarm

#### Service



Current status of HB50 hybrid water heater



Displays model & serial nos., SW version; change network instance or run a test



Shows temperatures in tank, ambient air, suction, evaporator and discharge



Displays current alarms and past alarms; ability to clear all alarms

#### Enabled



Press to toggle between Enabled & Standby  
• Enabled: heats water  
• Standby: doesn't heat water  
Note: "Modes" can't be selected when unit is in "Standby"



### Heat Pump Only Mode: Tank Recovery

Rheem Hybrid (50 gal) vs. Competitor Hybrid (50 gal)

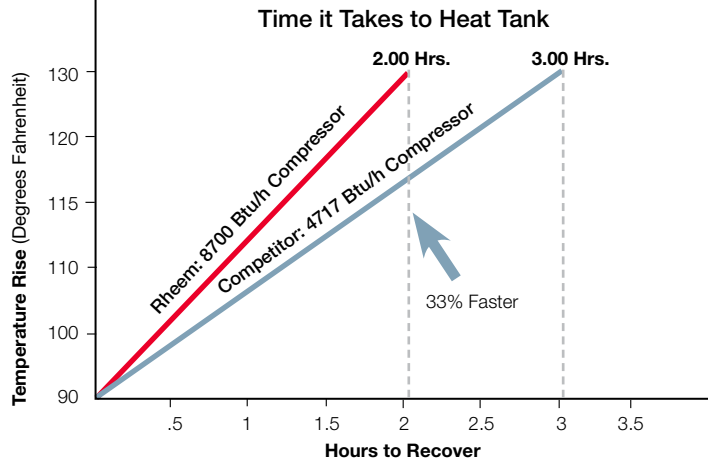

In keeping with its policy of continuous progress and product improvement, Rheem reserves the right to make changes without notice.

Rheem Water Heating • 101 Bell Road  
Montgomery, Alabama 36117-4305 • 1.800.621.5622

Rheem Canada Ltd./Ltée • 125 Edgeware Road, Unit 1  
Brampton, Ontario L6Y 0P5 • 1.800.268.6966



INTEGRATED HOME COMFORT